

CASTOLDI JET

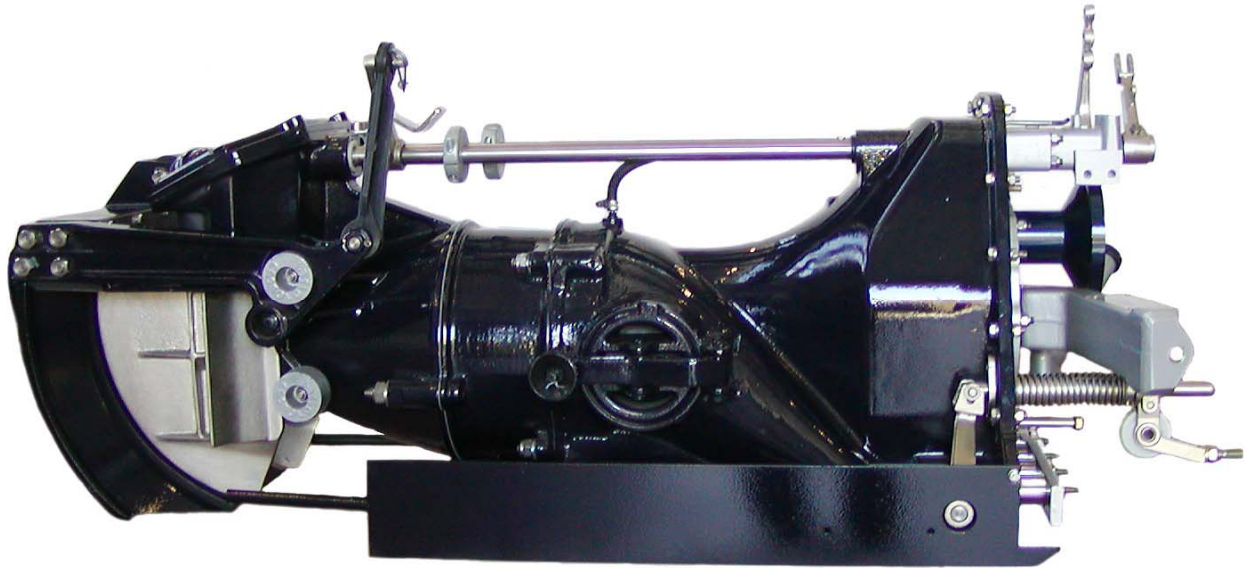

TURBODRIVE

238

Spare parts

La CASTOLDI S.p.A. si riserva il diritto di apportare in qualsiasi momento e senza preavviso eventuali modifiche di componenti ed accessori che ritiene necessarie per esigenze tecniche o commerciali, senza ritenersi impegnata ad aggiornare questa pubblicazione.

CASTOLDI SpA. withhold the right to introduce, at any time and without previous notice, such modifications of components and accessories as might be deemed necessary for technical or commercial reasons, without any obligation to bring up-to-date this manual.

ATTENZIONE! Prima di ordinare pezzi di ricambio rilevare il numero di matricola del motore o del jet e consultare il catalogo tenendo presente che le modifiche sono introdotte nelle tavole d'aggiornamento con il numero di matricola della prima macchina che porta la modifica, se questa comporta l'impiego di pezzi non intercambiabili con quelli precedenti.

ATTENZION! *Before ordering spare, take the serial number of the engine, or of the jet, and look up the catalogue, keeping in mind that all variations are listed in the apposite tables that keep it up-to-date, with the serial number of the first piece of machinery to which the variation applies, if it involves the use of parts that are not interchangeable with the previous ones.*

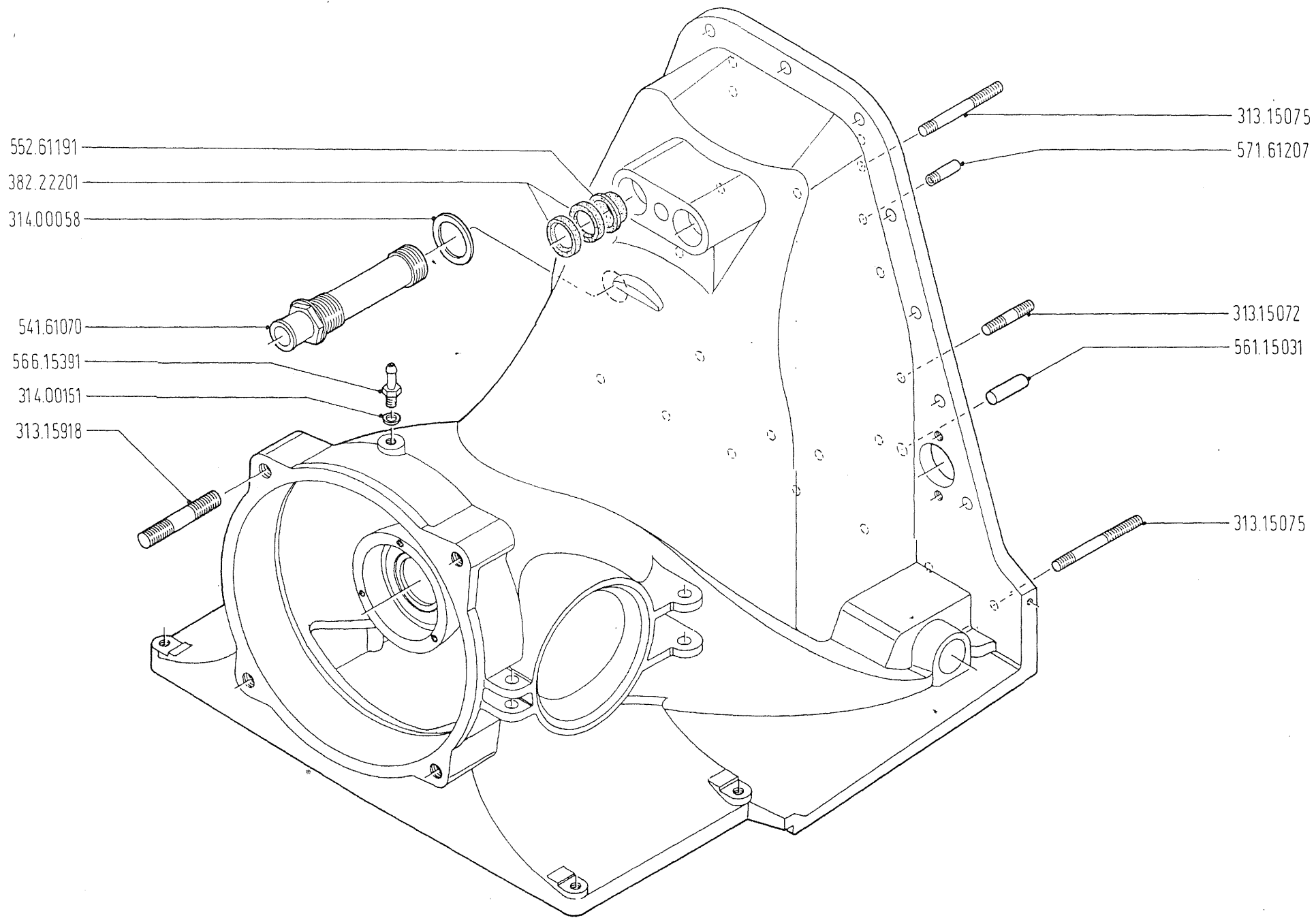

590.61033 - CORPO PROPULSORE COMPLETO
 COMPLETE JET UNIT CASING

17.01/02

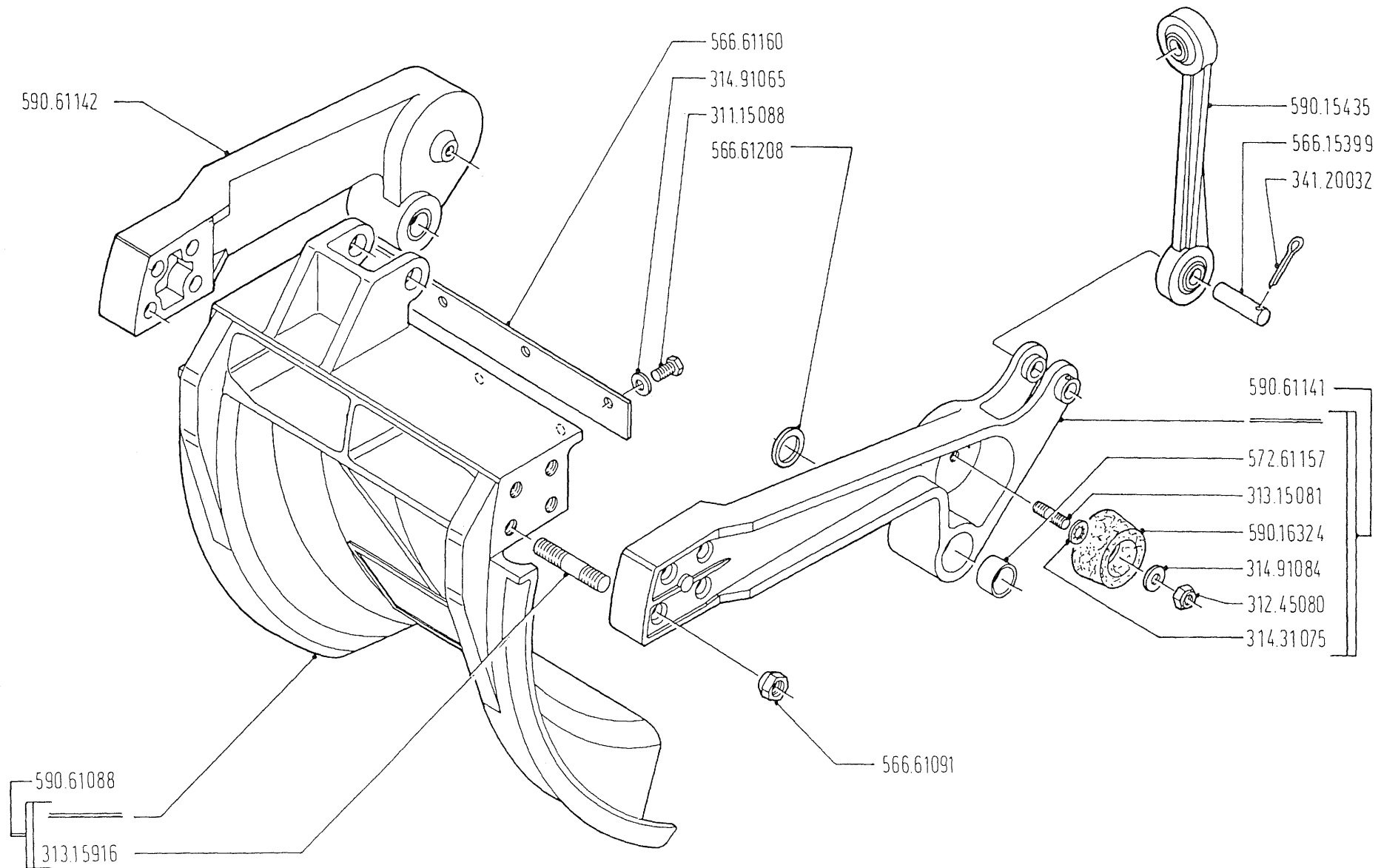

17.02/03

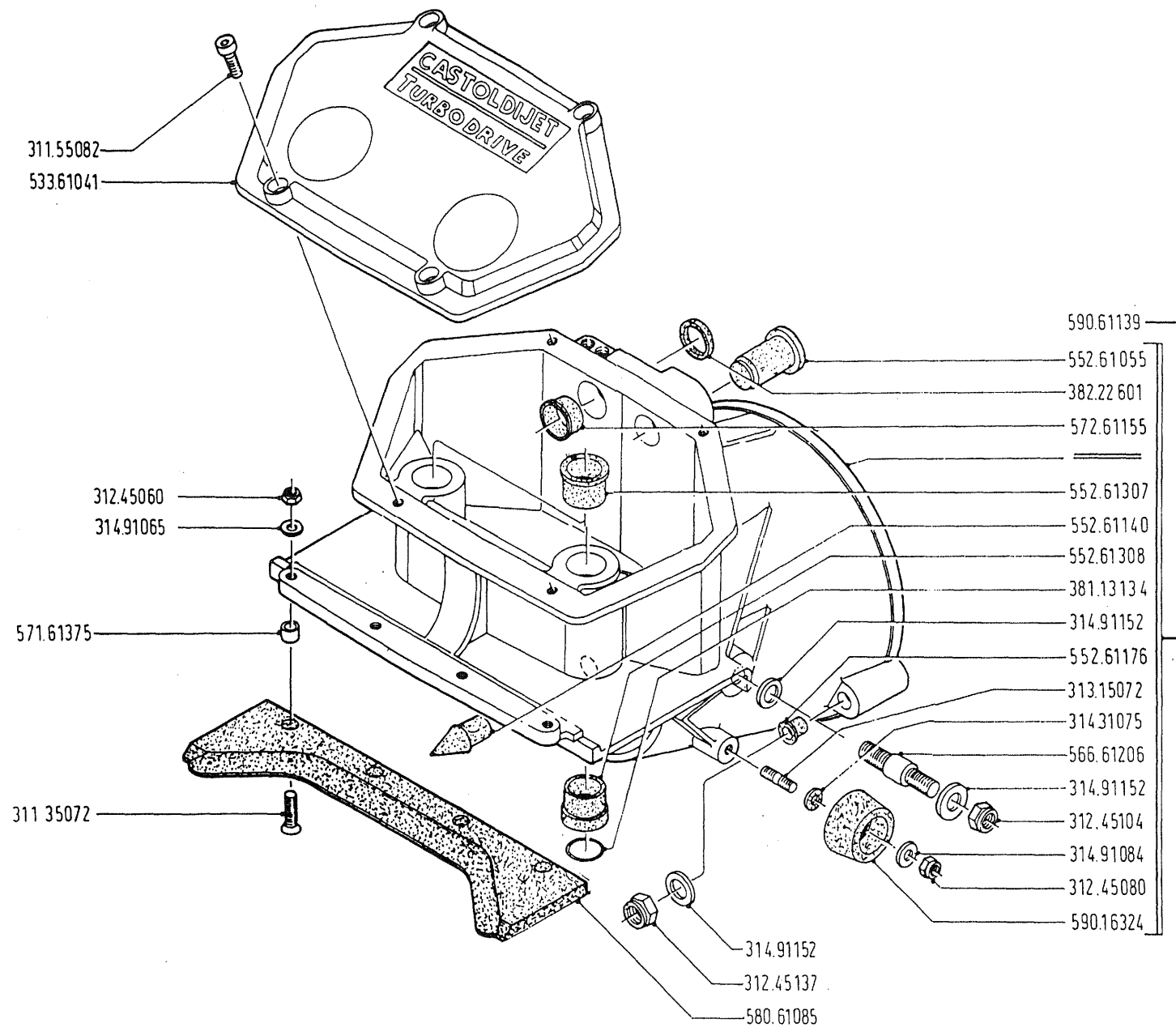

17.03/03

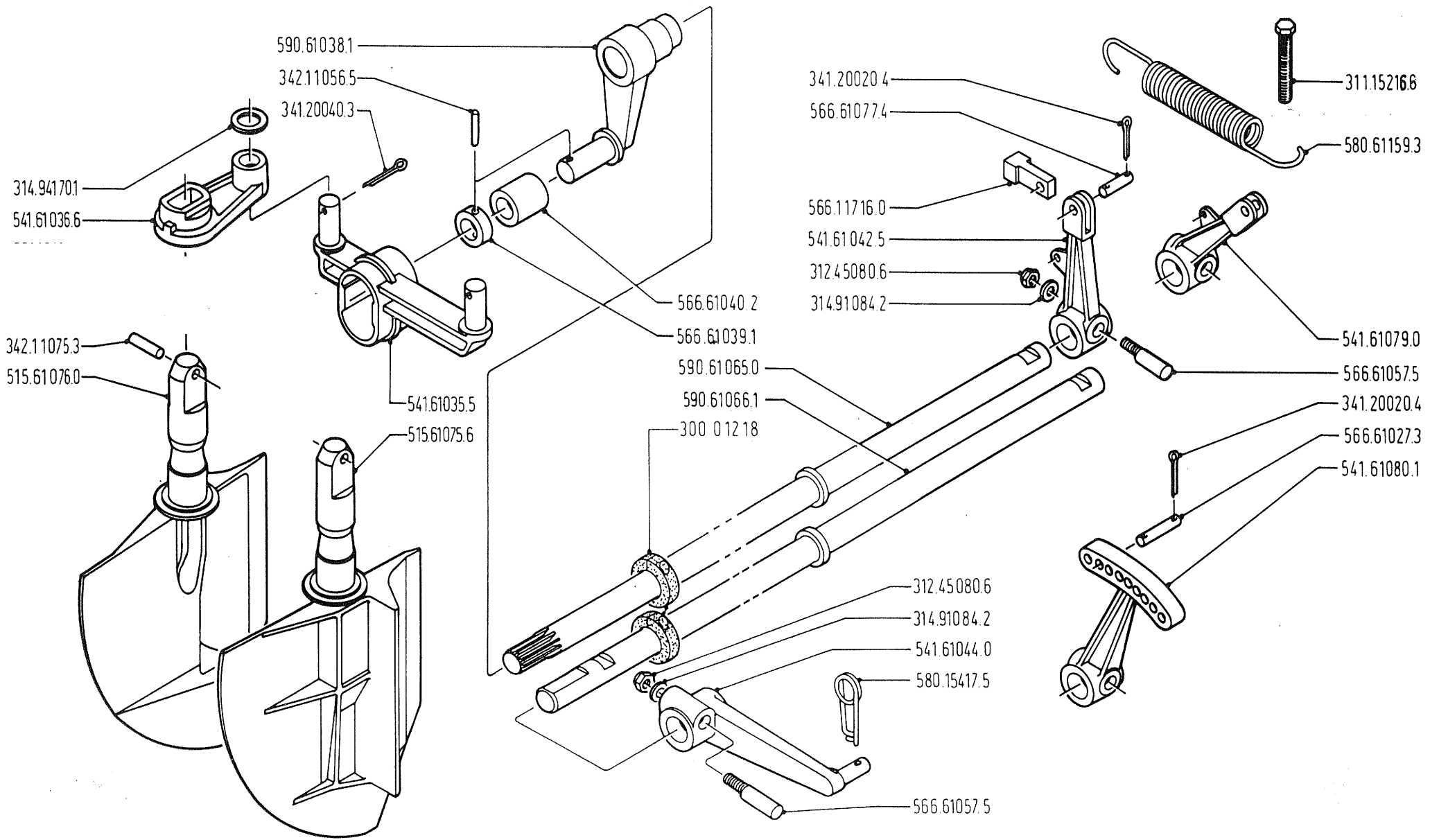

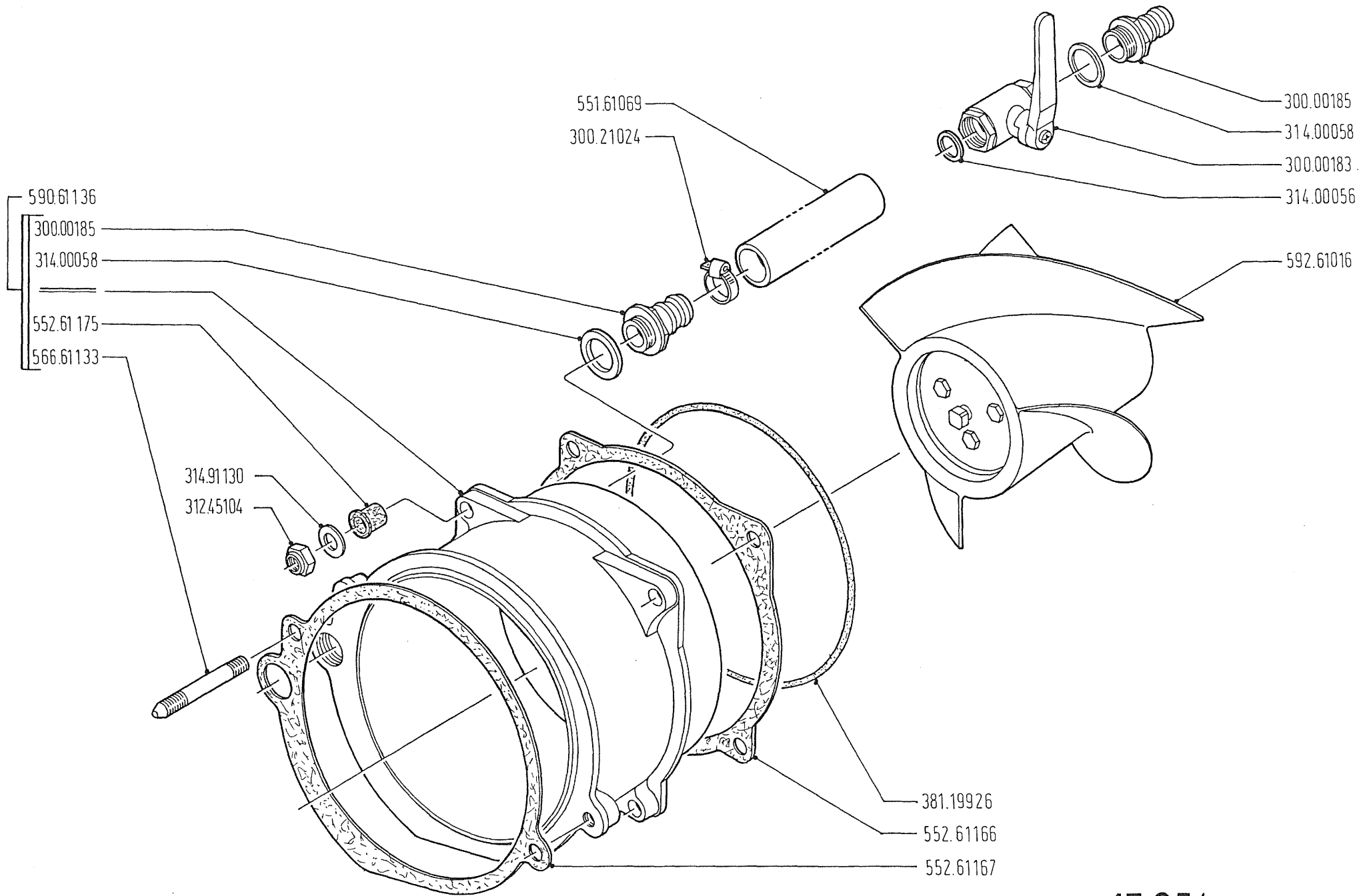

17.05/01

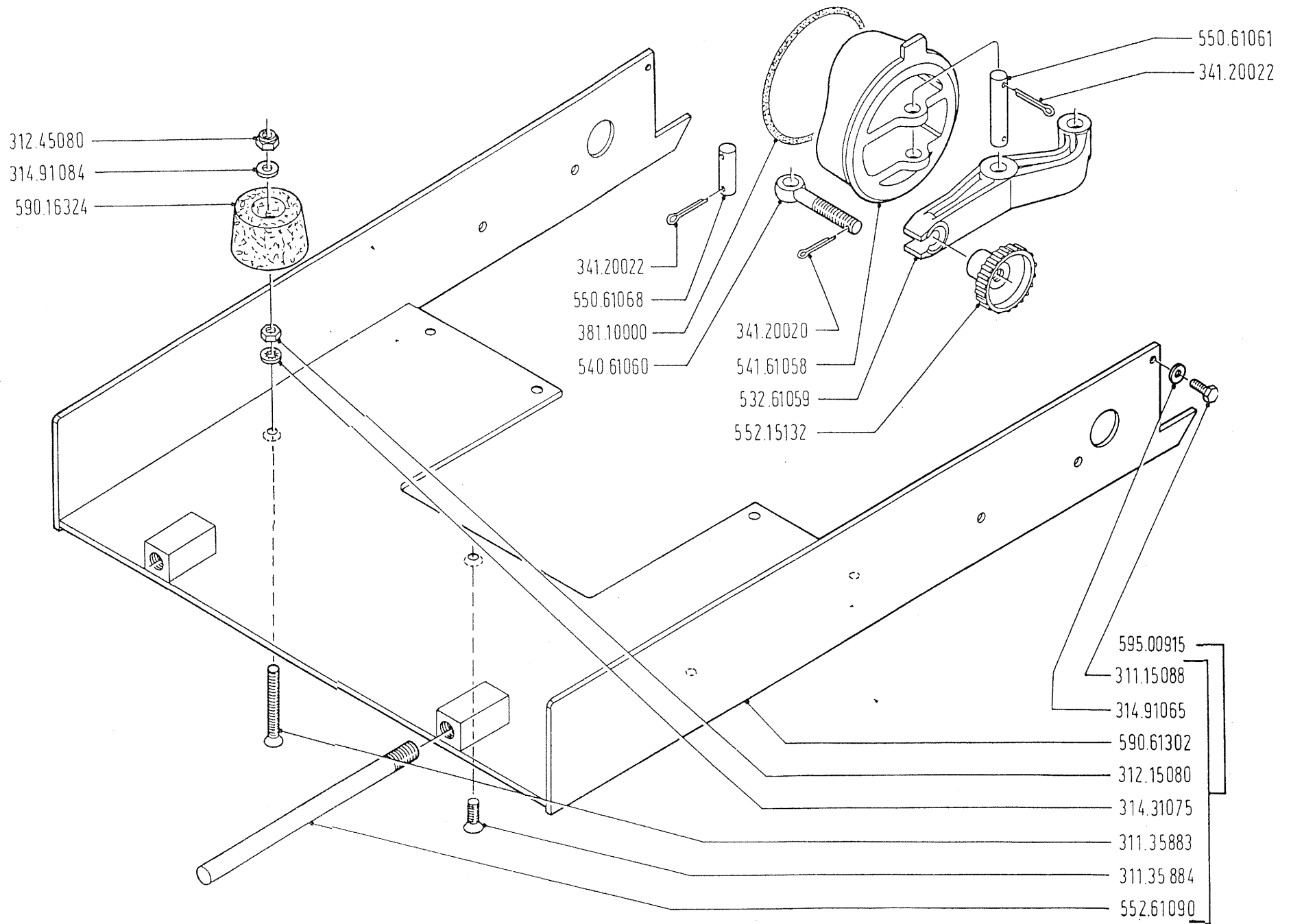

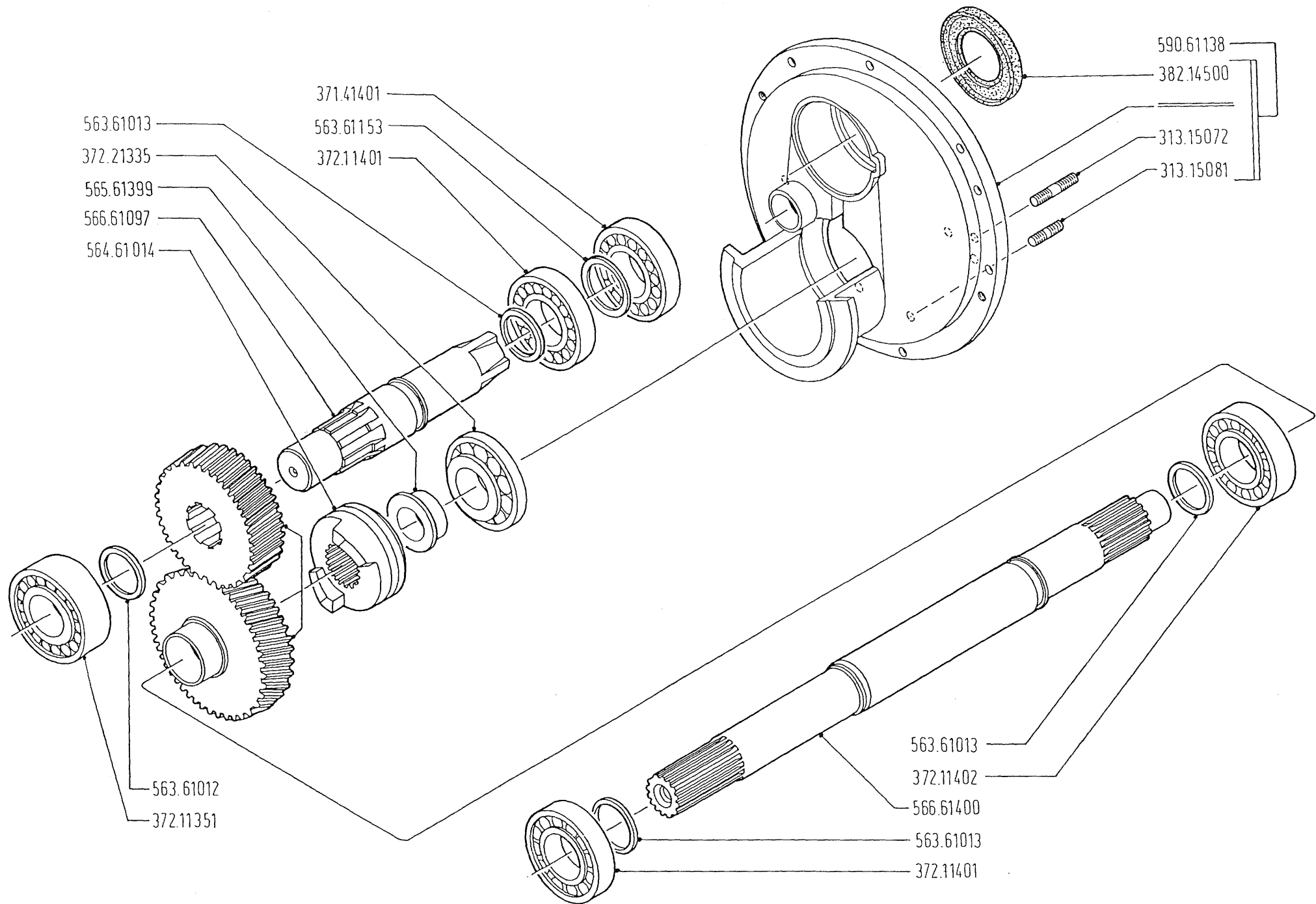

17.07/04

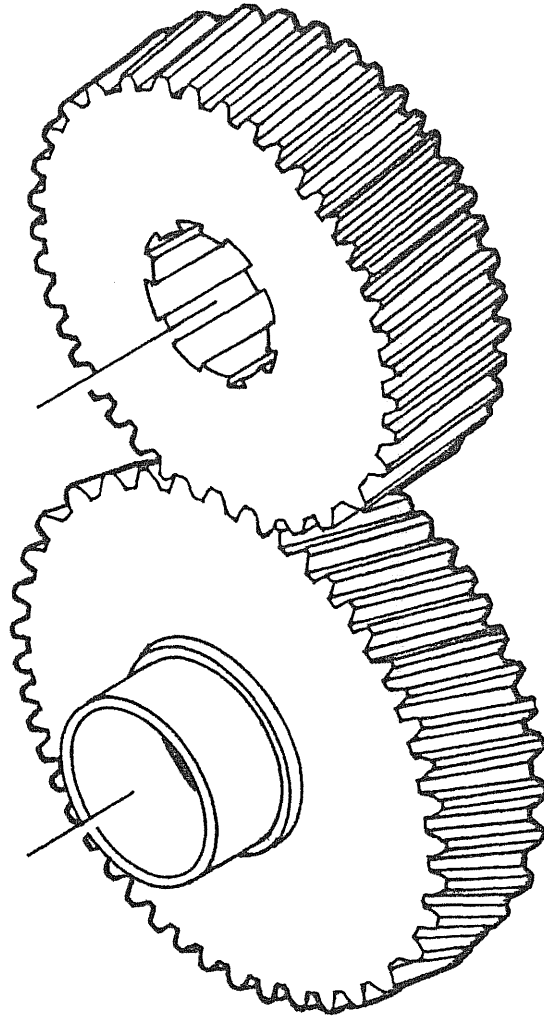

RAPPORTO GEAR RATIO	CODICE SET OF GEARS CODE NUMBER
19-54	592.61108.4
20-53	592.61109.5
21-52	592.61110.6
22-51	592.61111.0
23-50	592.61112.1
24-49	592.61113.2
25-48	592.61114.3
26-47	592.61115.4
27-46	592.61116.5
28-45	592.61117.6
29-44	592.61118.0
30-43	592.61119.1
31-42	592.61120.2
32-41	592.61121.3
33-40	592.61122.4
34-39	592.61123.5
35-38	592.61124.6
36-37	592.61125.0
37-36	592.61126.1
38-35	592.61127.2
39-34	592.61128.3
40-33	592.61129.4
41-32	592.61130.5
42-31	592.61131.6
43-30	592.61132.0

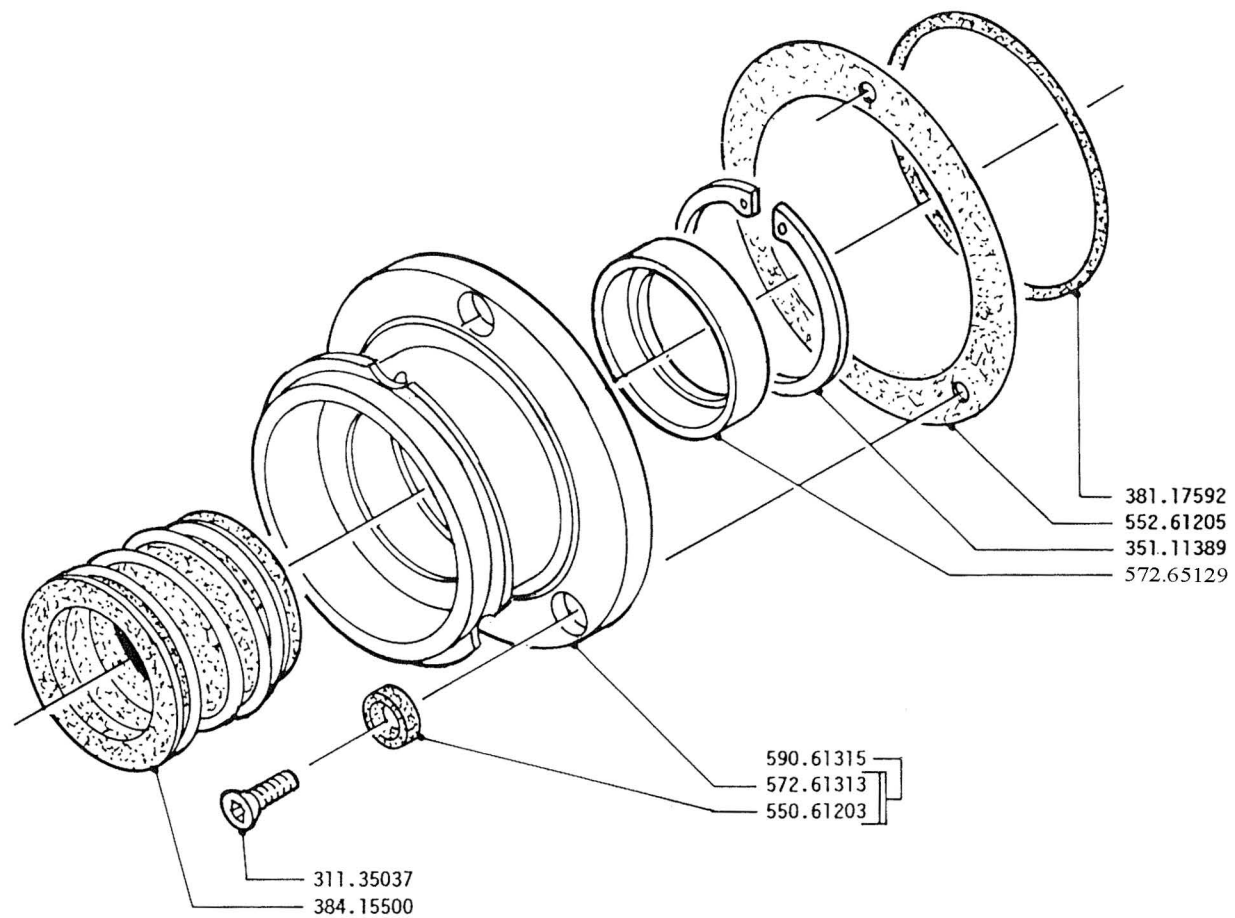

592.61254 - TENUTA PER ALBERO GIRANTE T.D. 238
T.D. 238 IMPELLER SHAFT SEAL

17.09/05

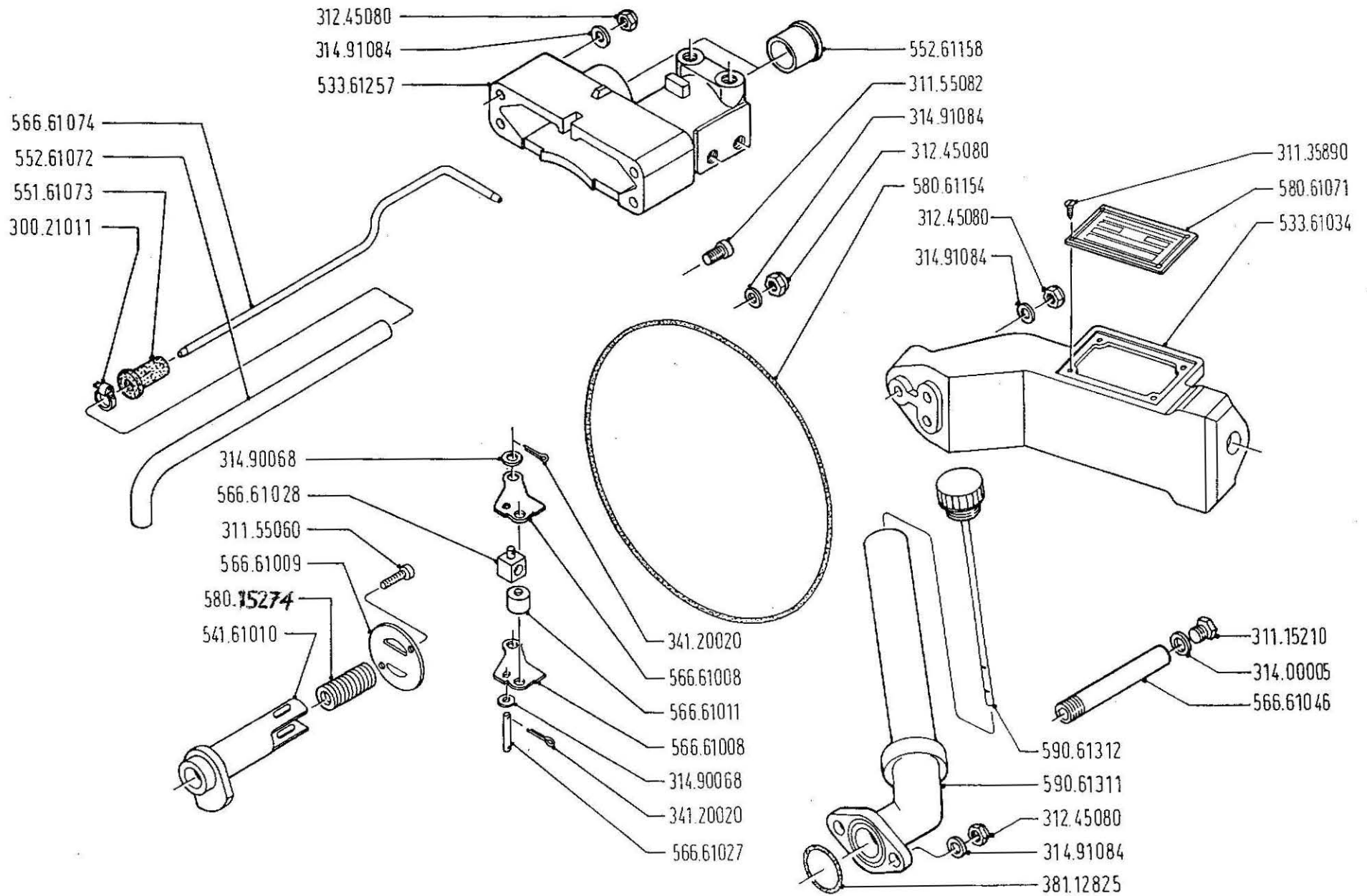

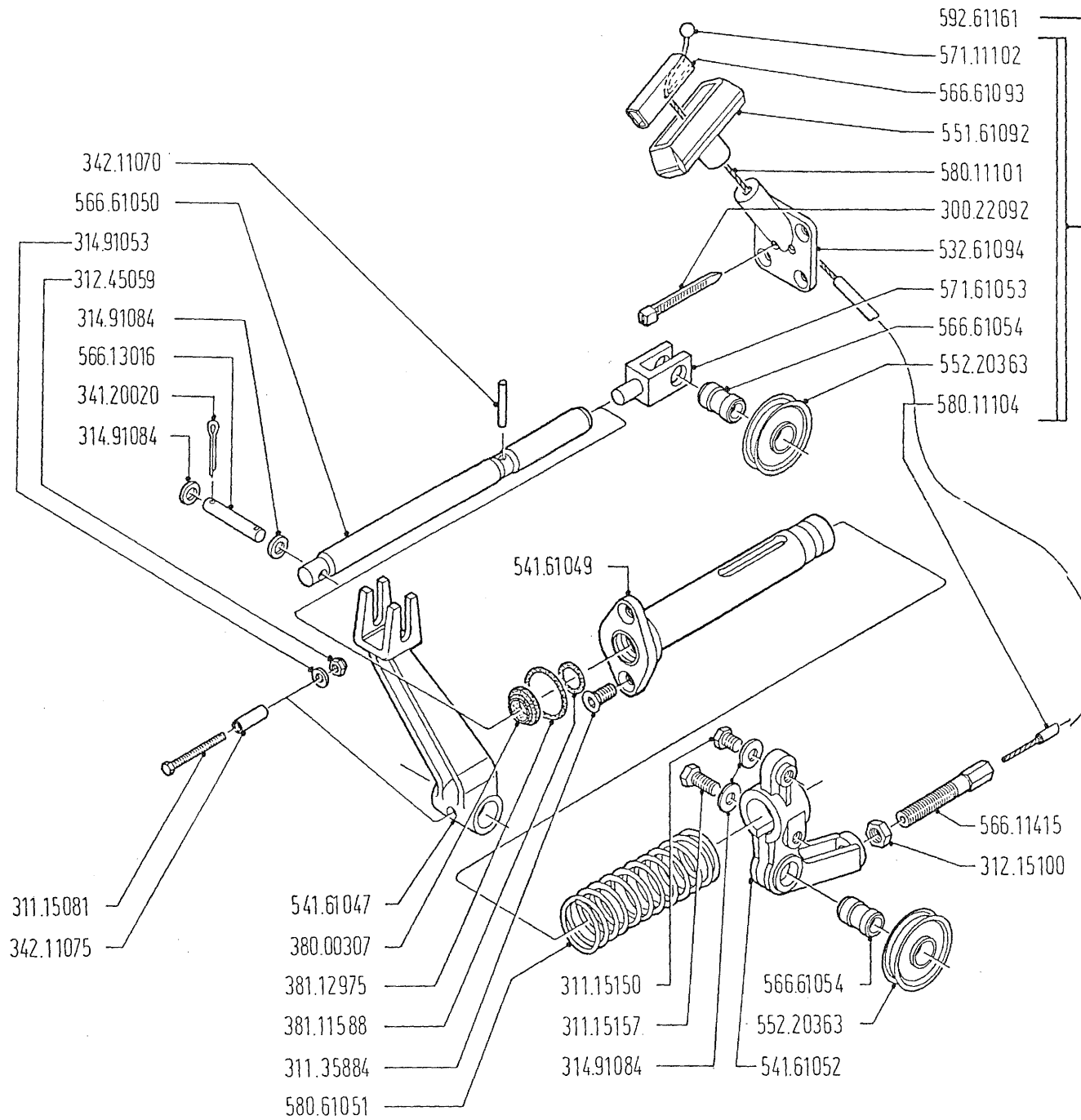

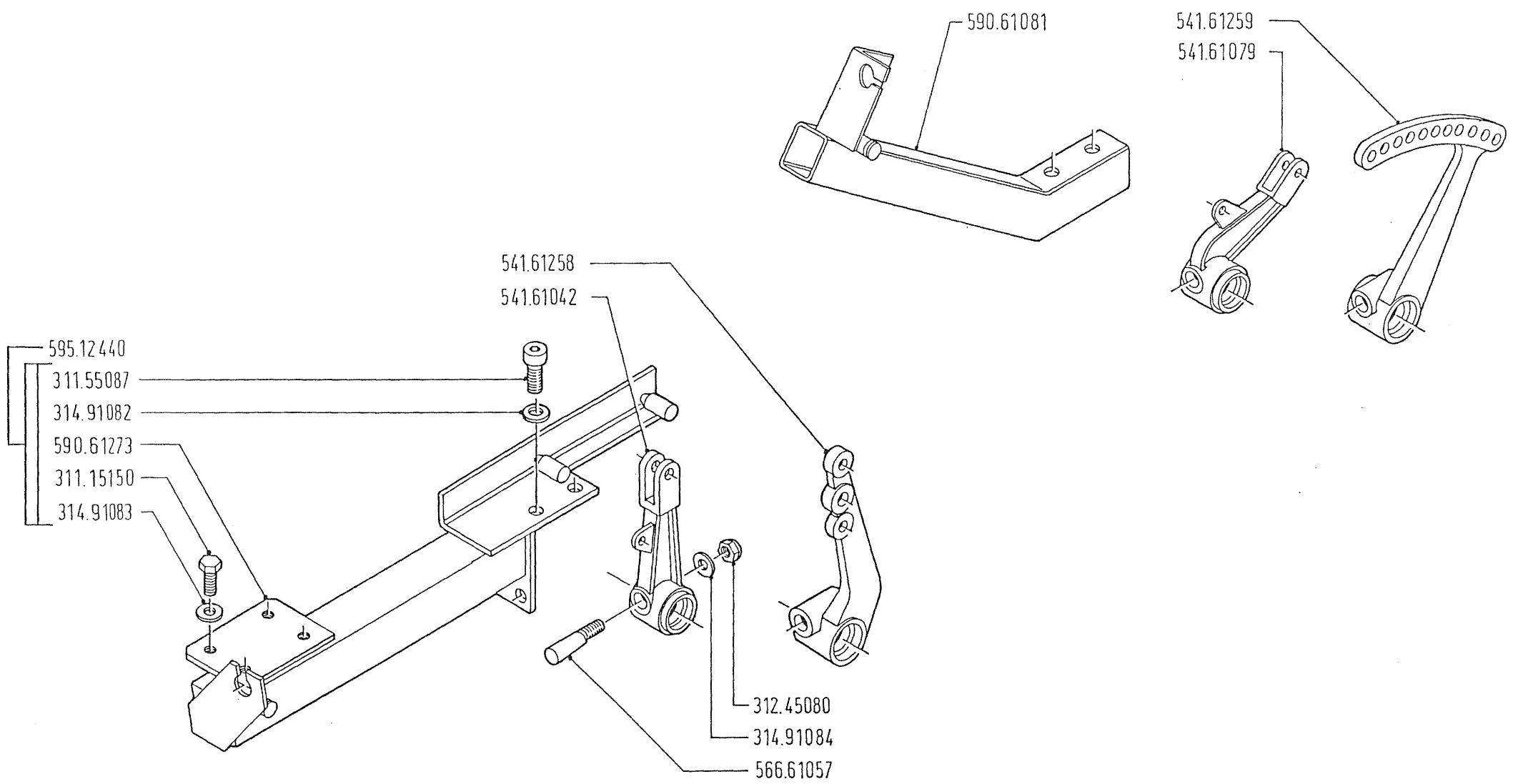

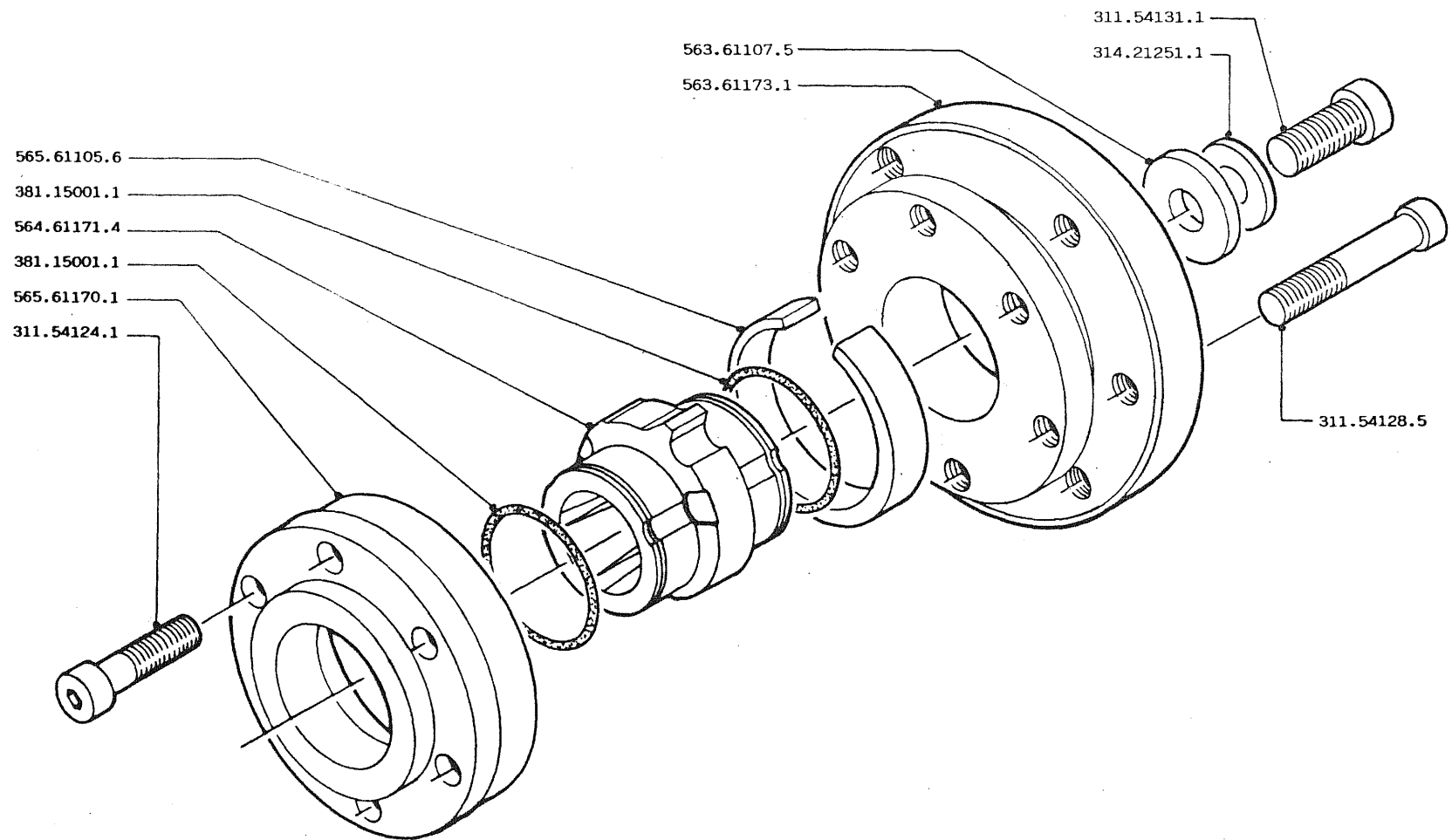

592.61101 - PARASTRAPPI COMPLETO PER GIUNTO OMOCINETICO 13740
- COMPLETE SHOCK ABSORBER FOR CONSTANT VELOCITY JOINT

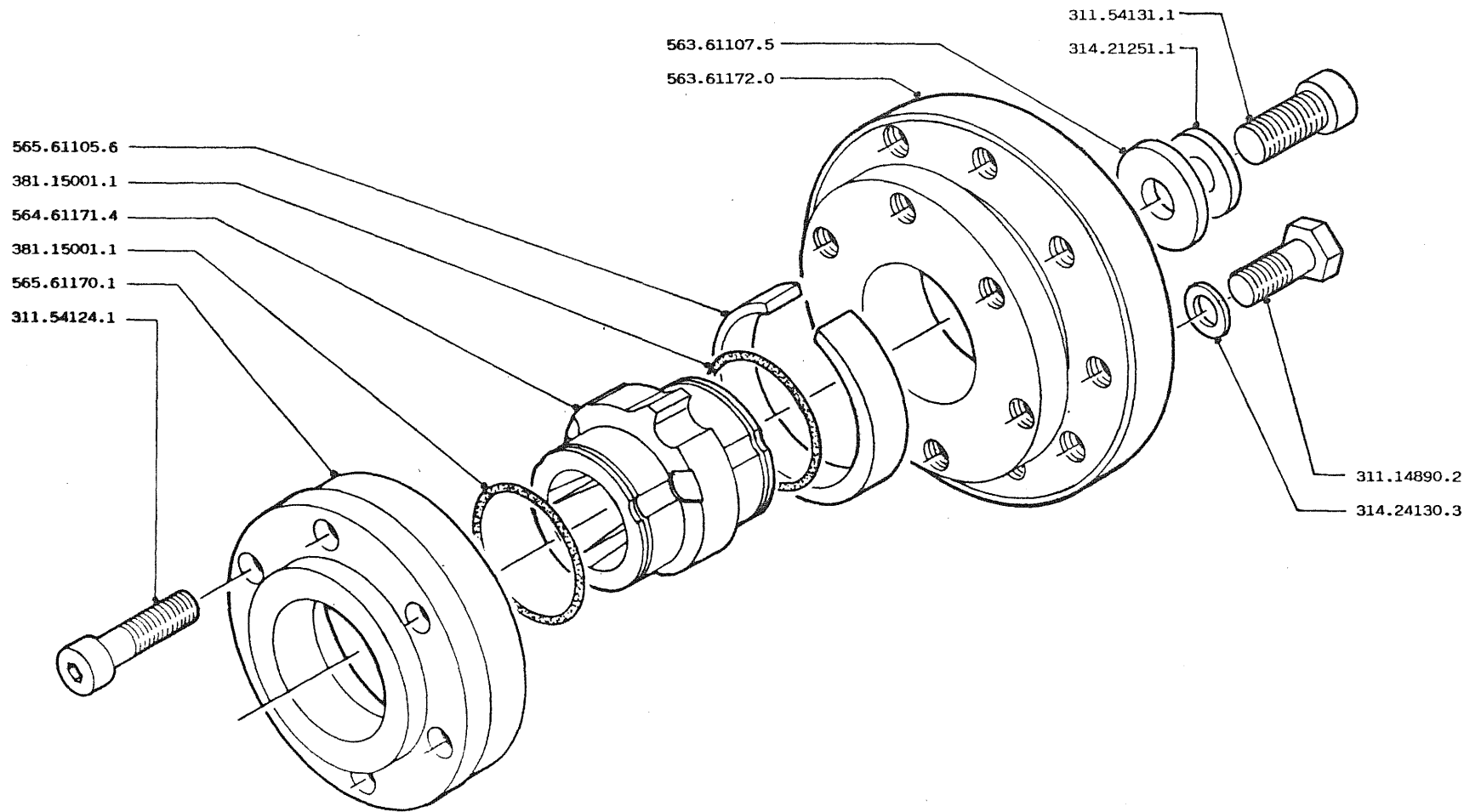

592.61100 - PARASTRAPPI COMPLETO ALBERO CARDANICO G.W.B. 587.15, 587.20, 587.30
 - COMPLETE SHOCK ABSORBER FOR G.W.B. 587.15, 587.20, 587.30 UNIVERSAL JOINT

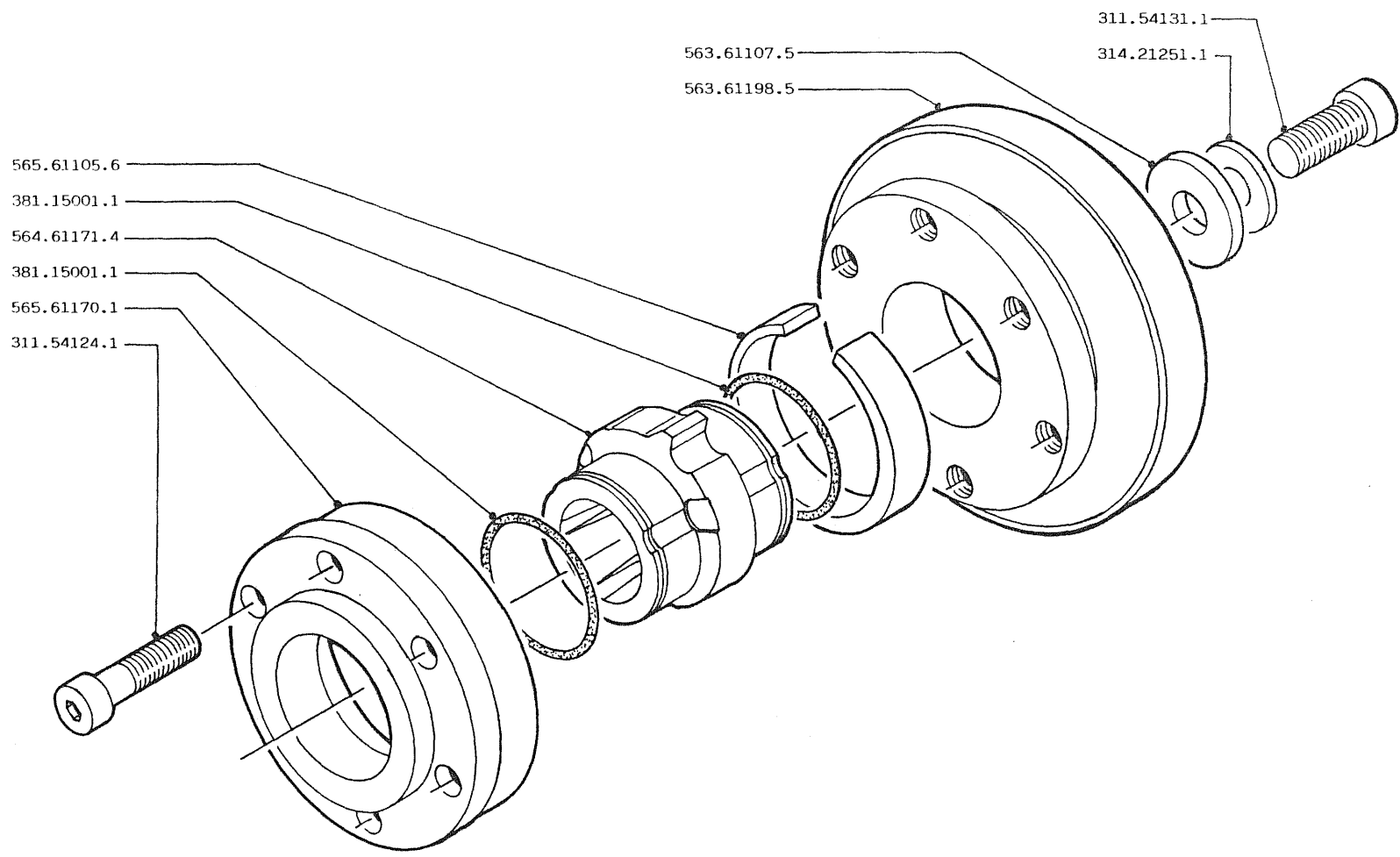

592.61199 - PARASTRAPPI COMPLETO FLANGIA SEMILAVORATA
 - COMPLETE SHOCK ABSORBER WITH BLANK FLANGE

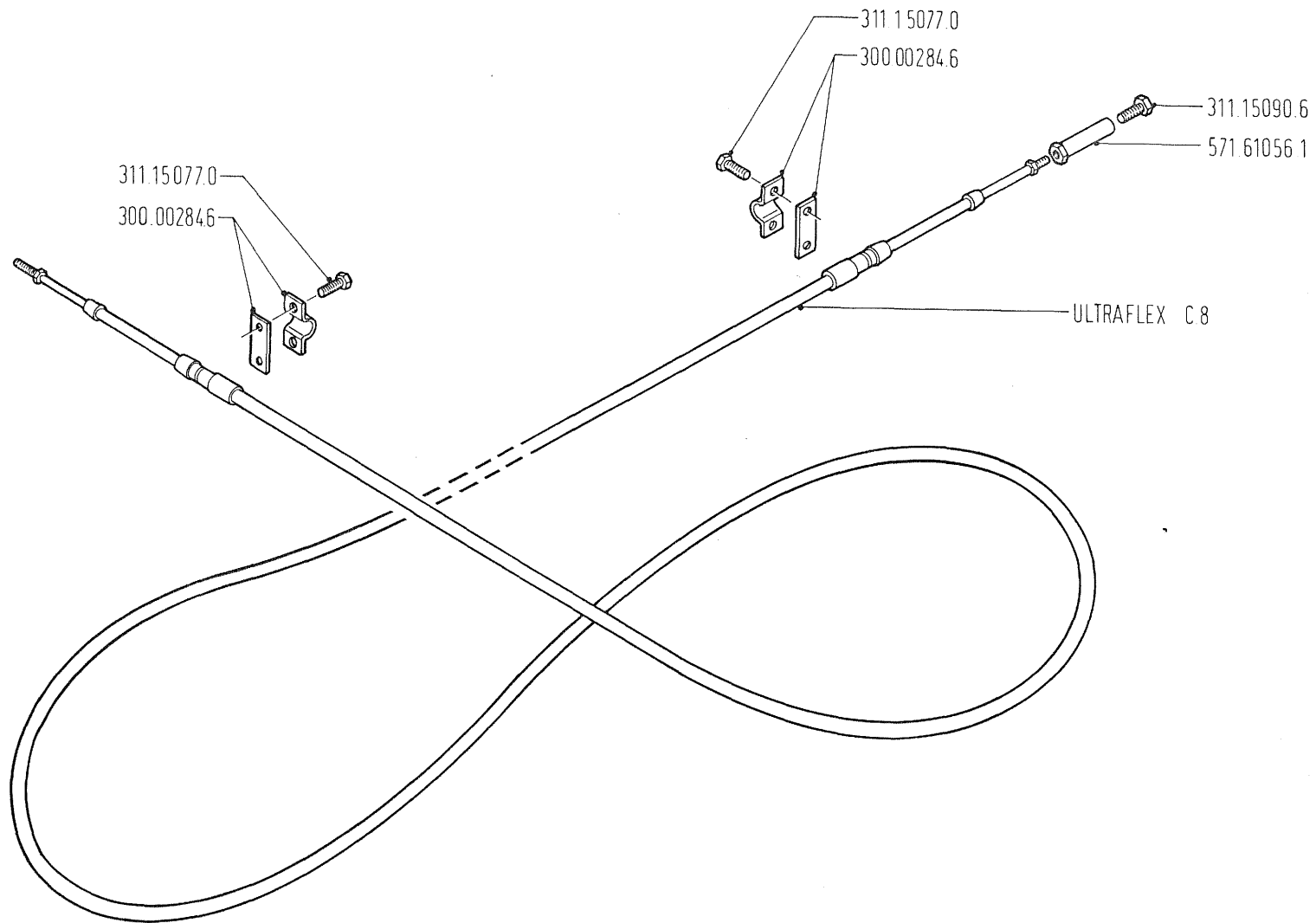

- 599.02872 - KIT ACCESSORI CAVO " ULTRAFLEX C8" PER COMANDO INNESTO IDROGETTO MOD. TD 238
 - KIT OF ACCESSORIES FOR "ULTRAFLEX C8" CLUTCH CONTROL CABLE FOR WATER JET UNIT MOD. TD 238

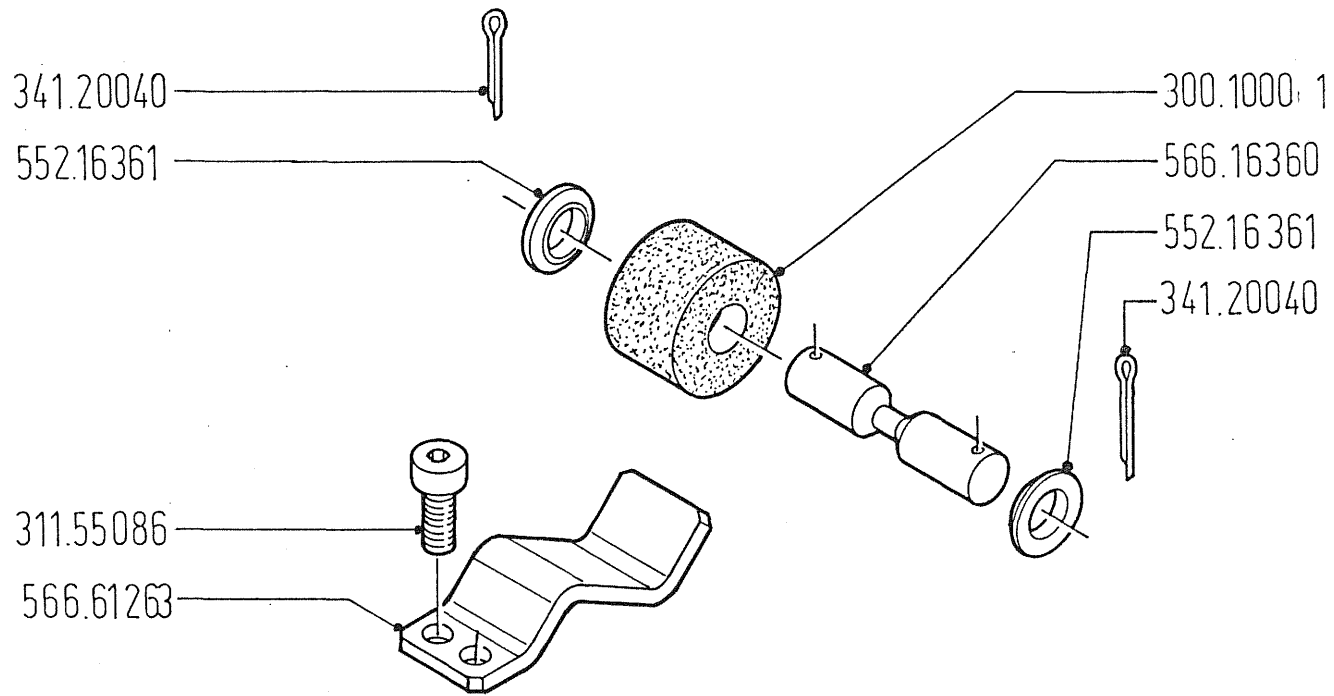

599.00907 - AGGANCIO ELASTICO PER DEFLETTORE
ELASTIC LOCK FOR REVERSING GATE

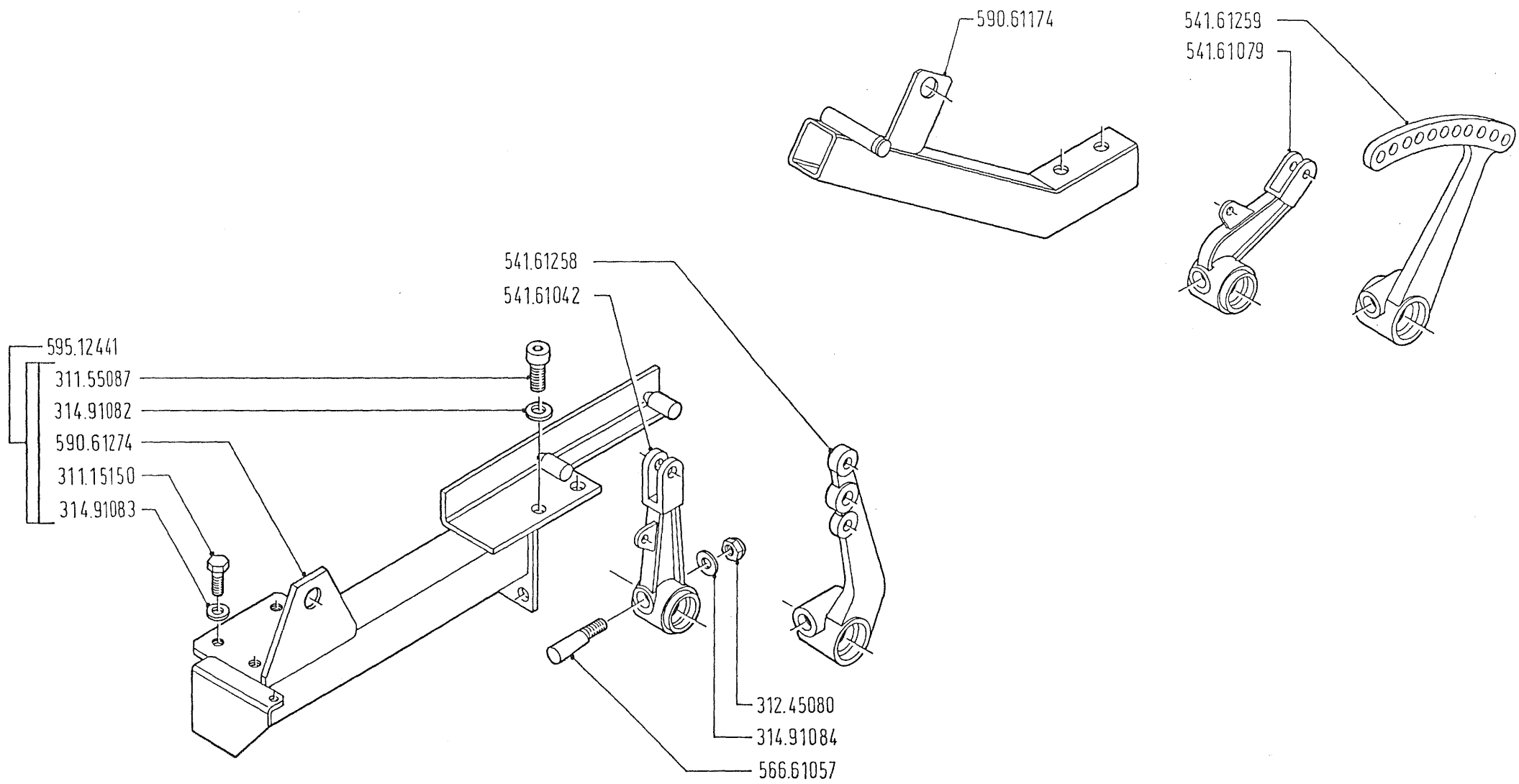

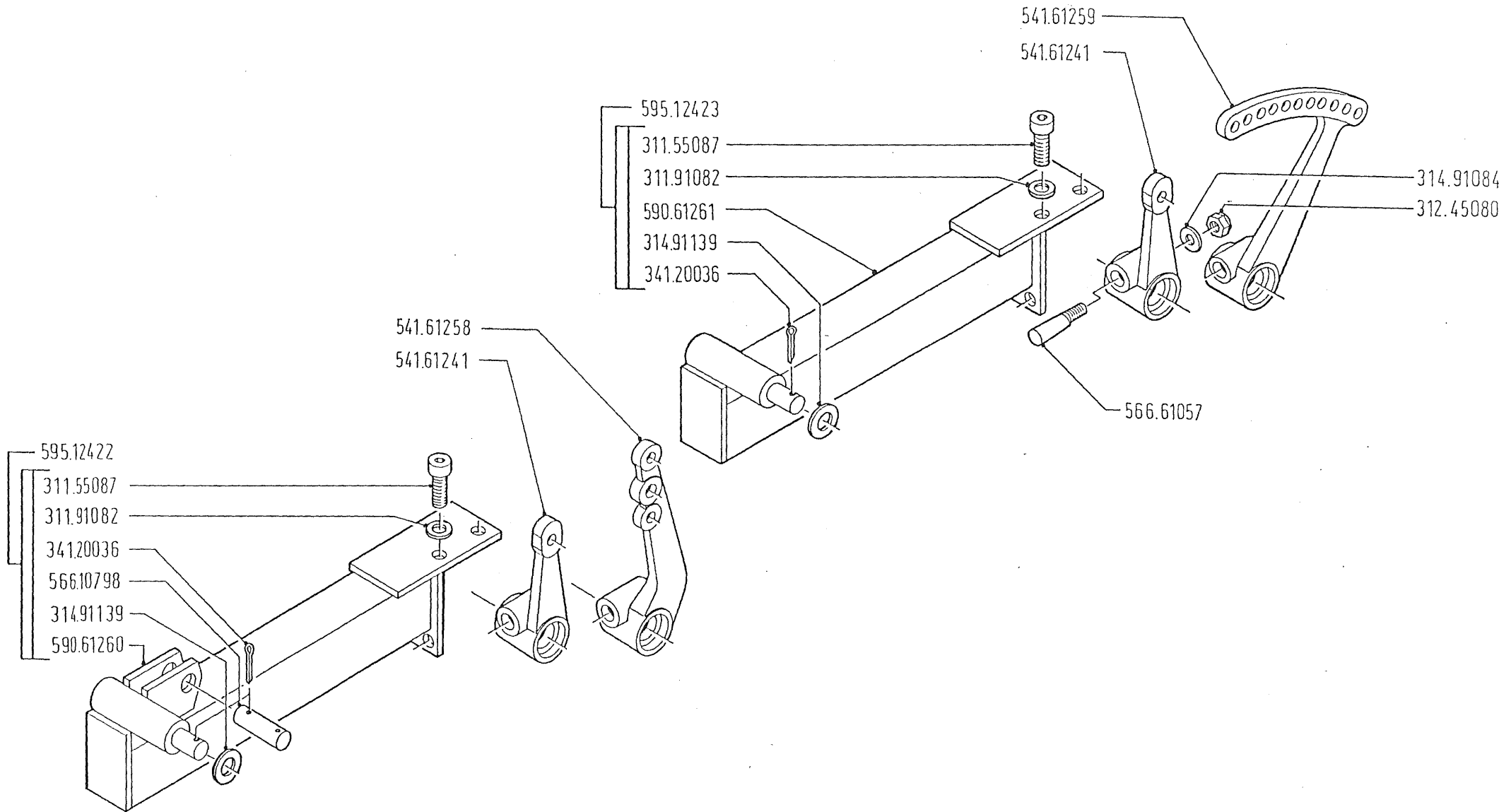

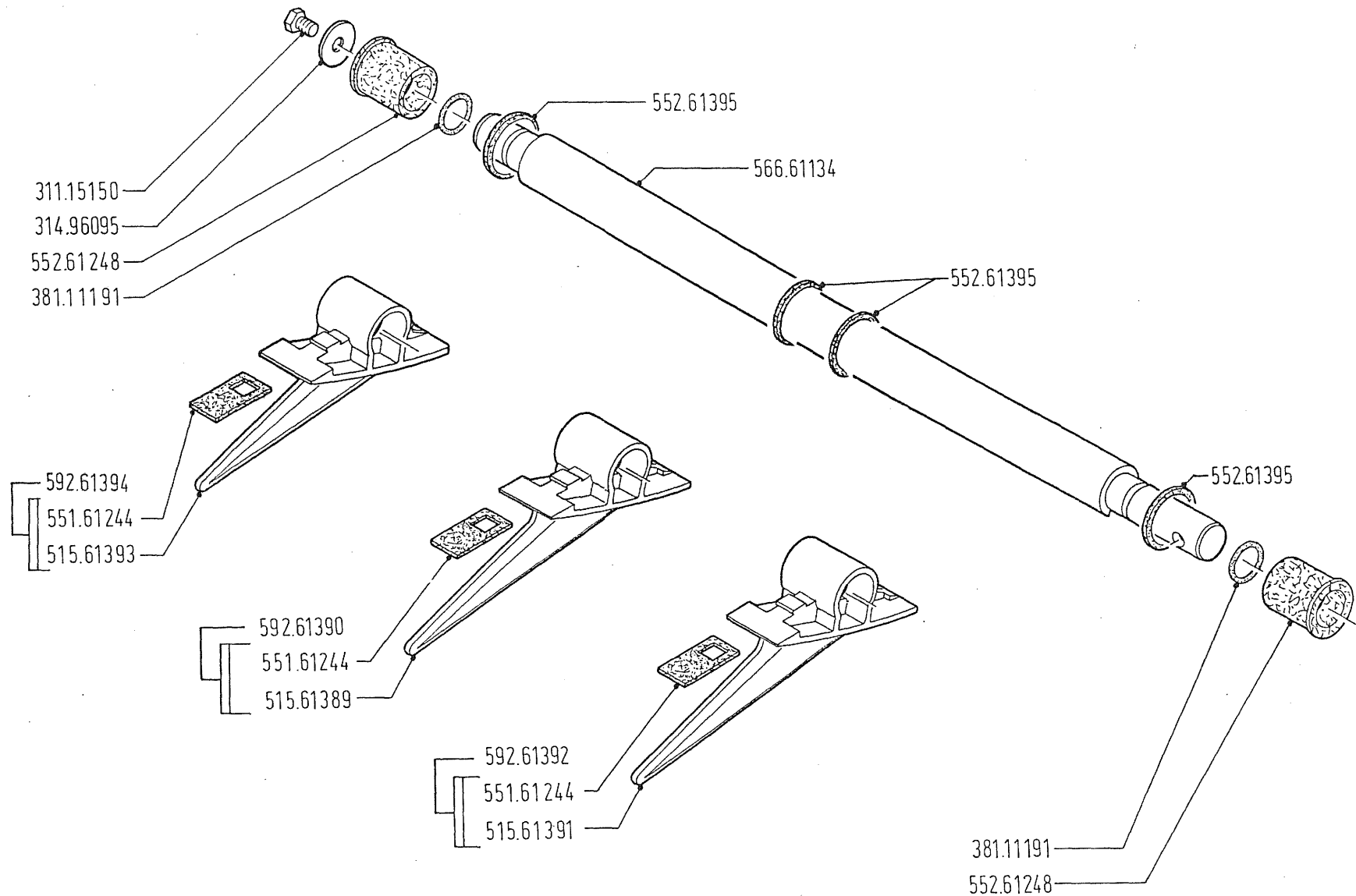

595.00057-GRIGLIA COMPLETA IDROGETTO T.D. 238
 -COMPLETE WEED RAKE FOR T.D. 238 JET UNIT

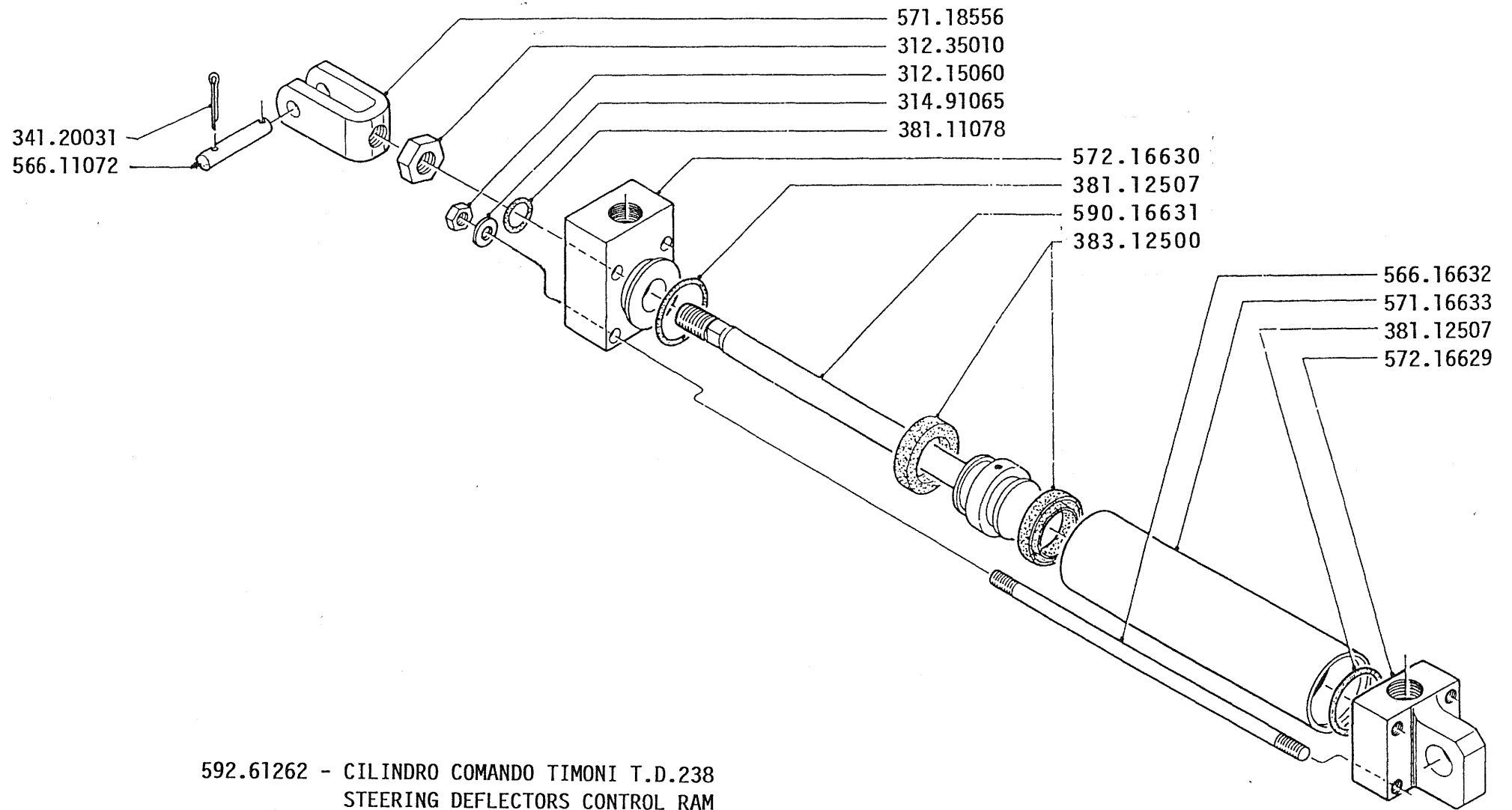

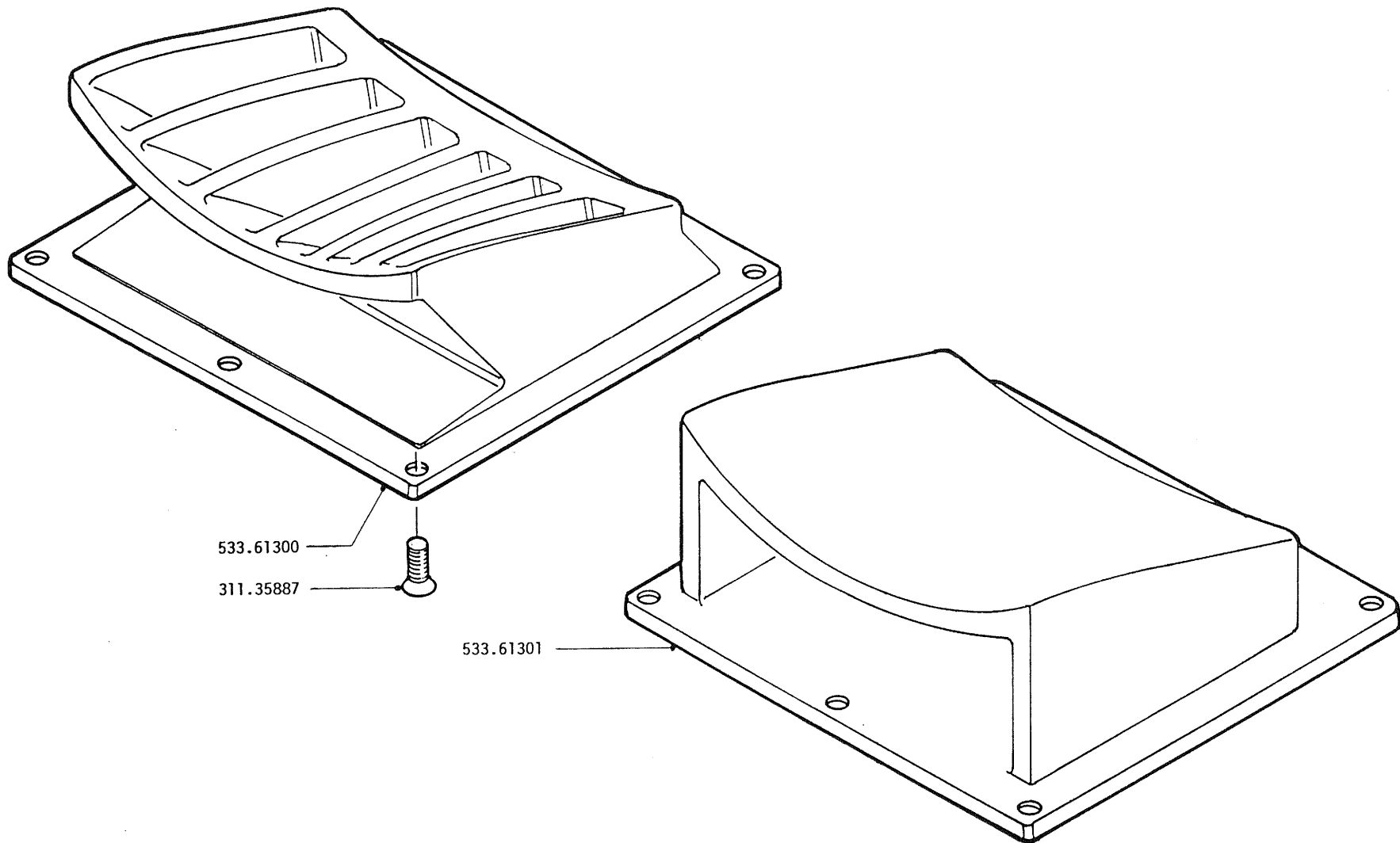

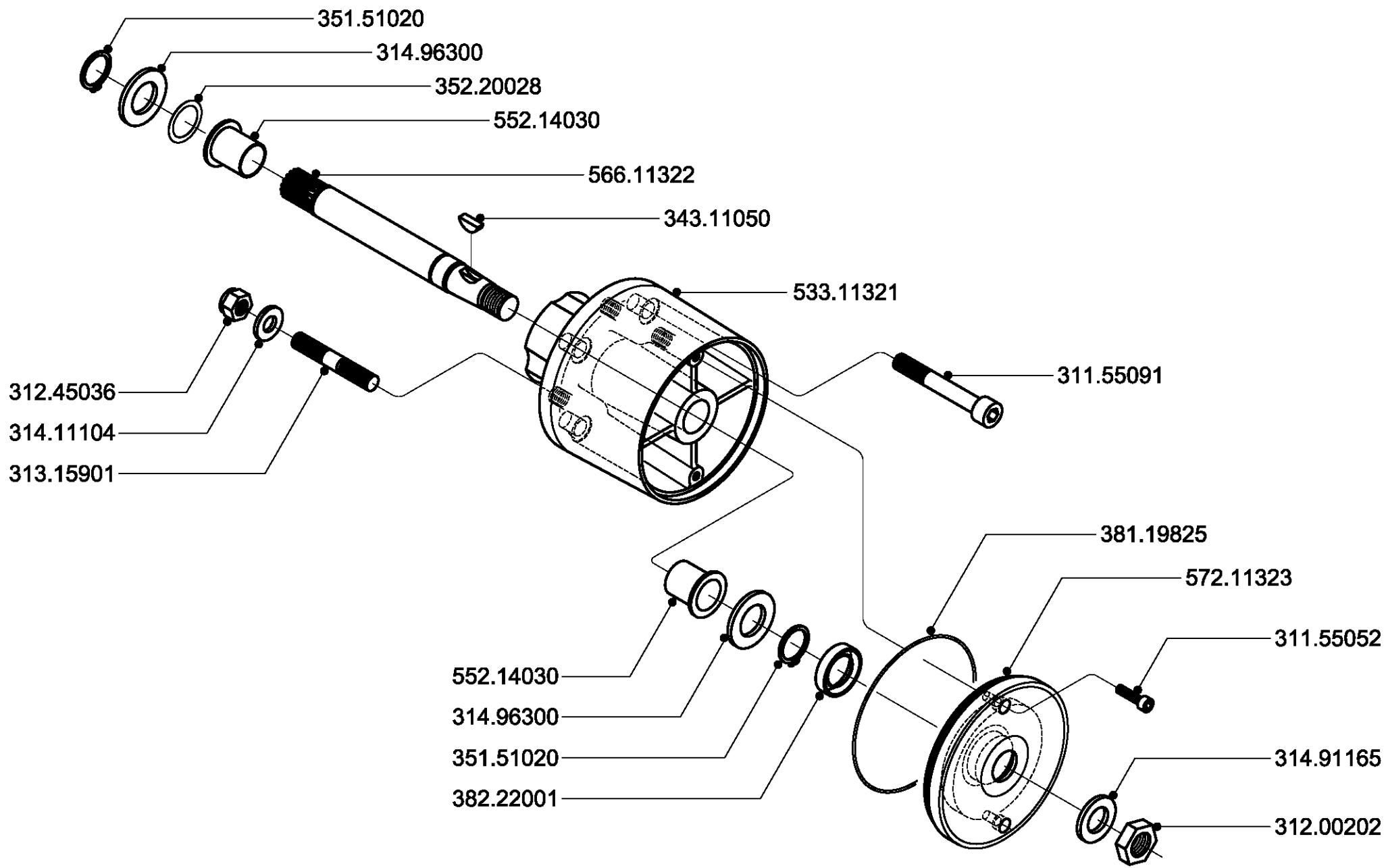

592.11320 - SUPPORTO VOLANTE COMPLETO con IDROGUIDA DANFOSS
 592.11320 - DANFOSS STEERING WHEEL SUPPORT ASSEMBLY

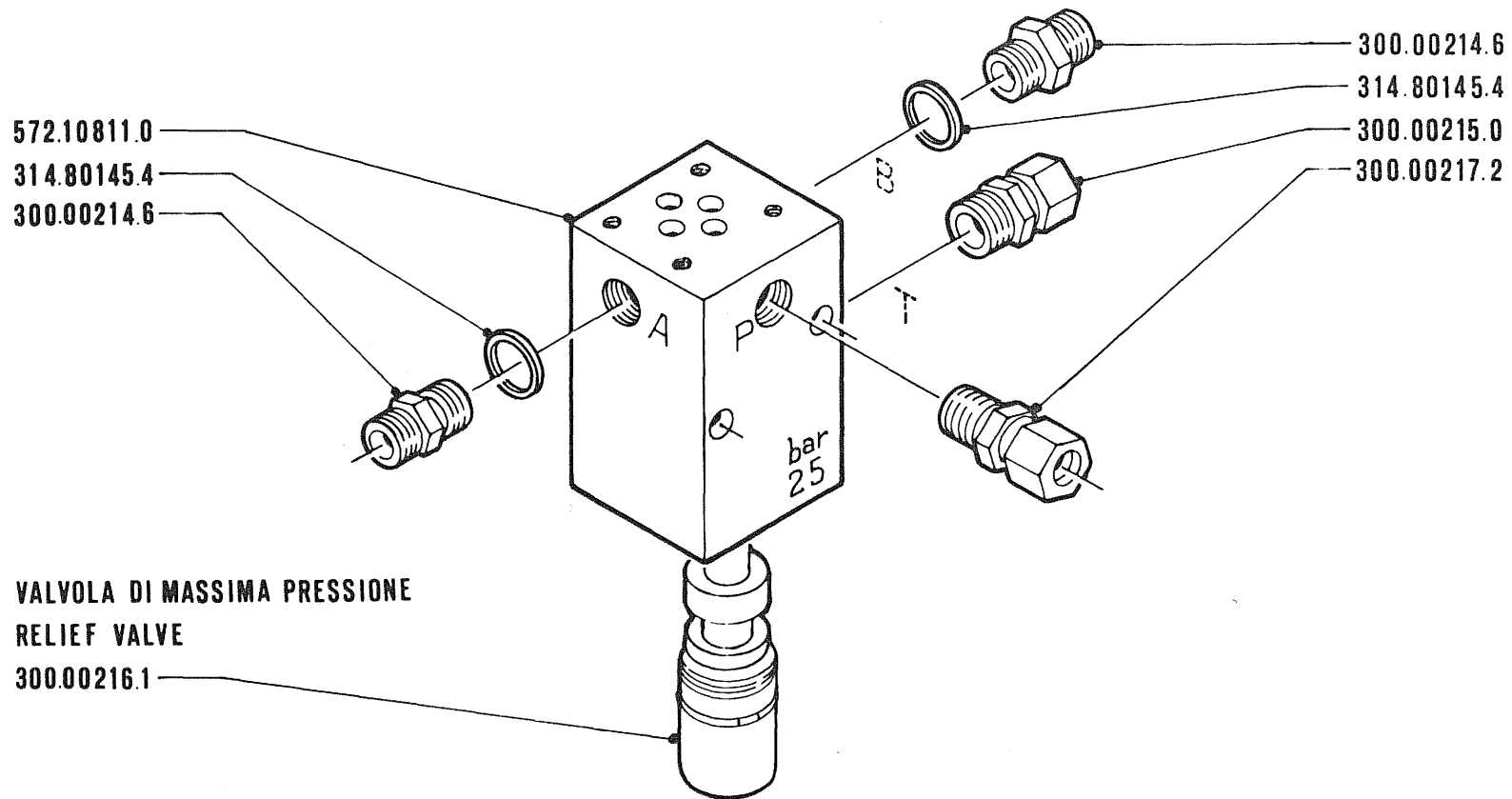

592.10810.1 - BASE ELETTROVALVOLA CON VALVOLA DI MAX 25 BAR
- SOLENOID VALVE CONNECTION BLOCK WITH 25 BAR RELIEF VALVE

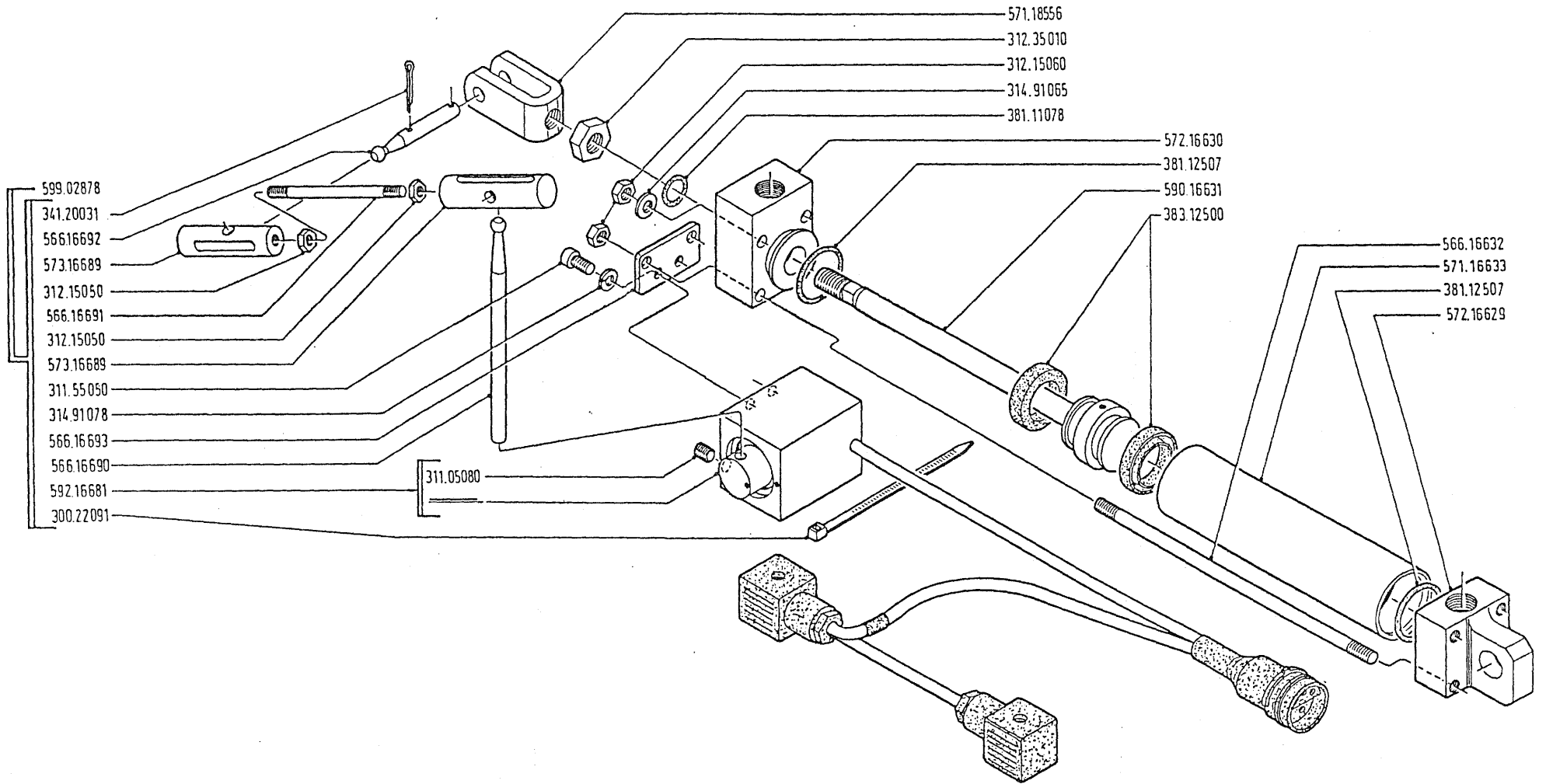

592.16628 - CILINDRO ELETTRIDRAULICO
 592.16628 - HYDRAULIC RAM

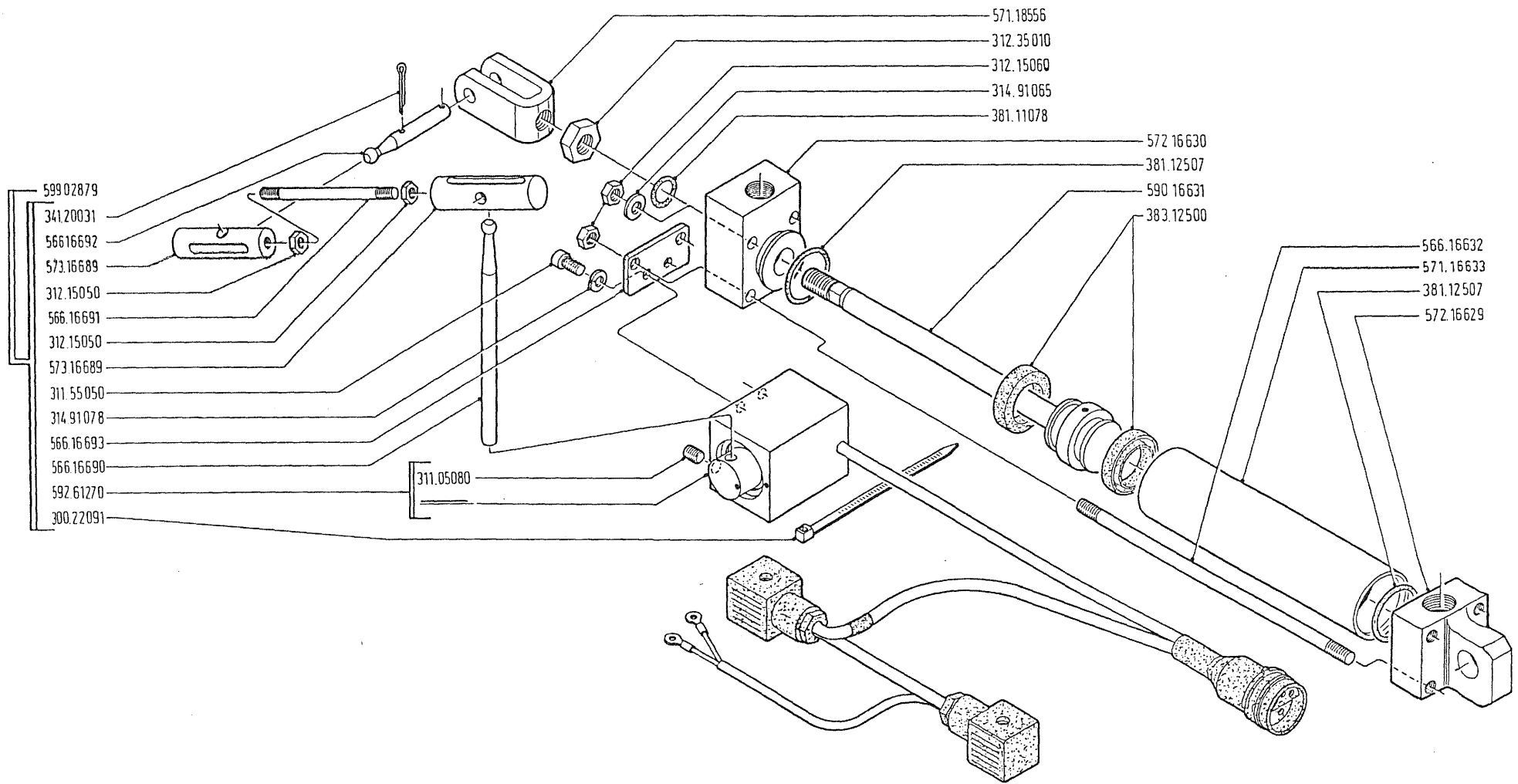

592.61250 - CILINDRO ELETTROIDRAULICO
HYDRAULIC RAM

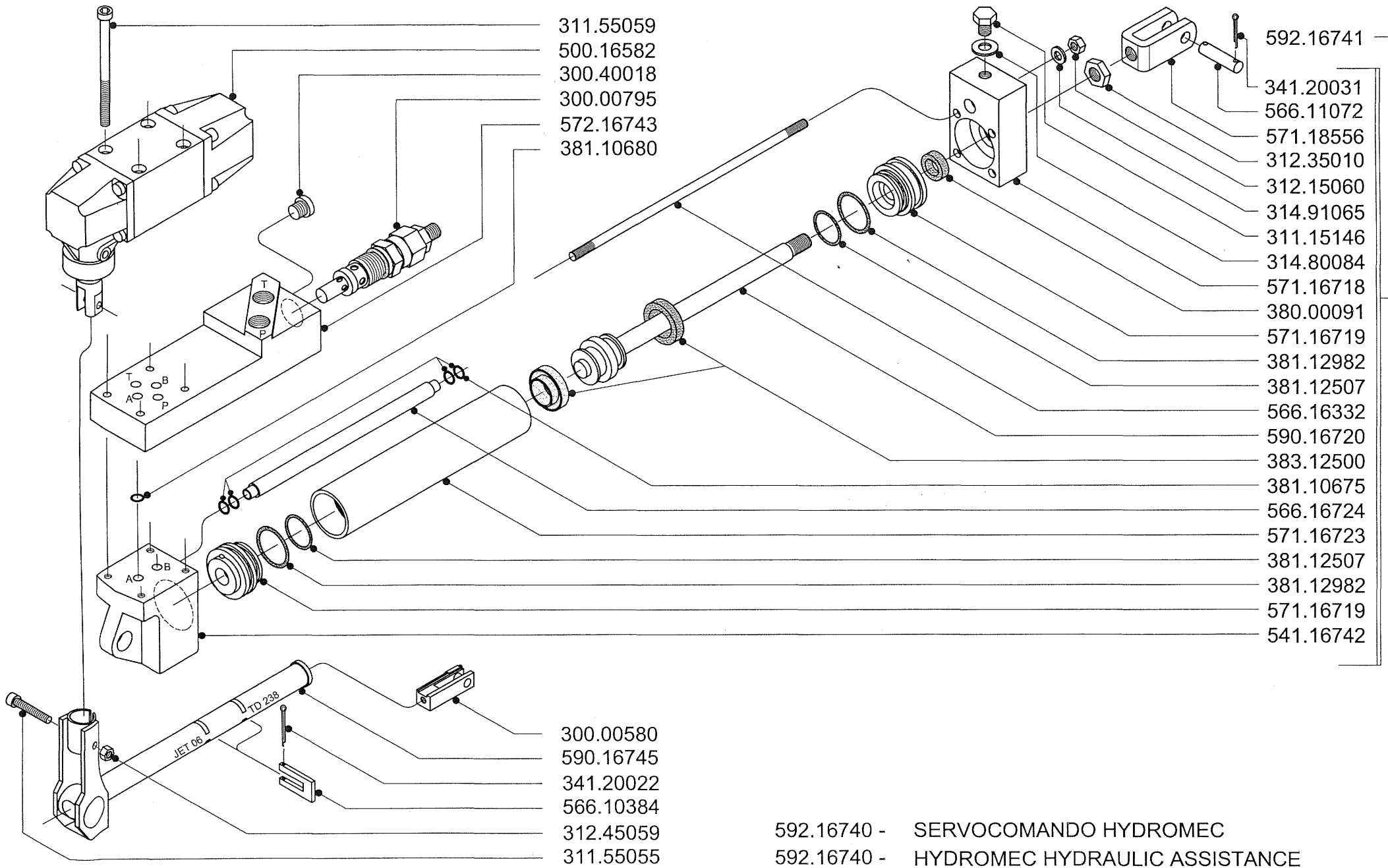

Castoldi S.p.A. withhold the right to introduce, at anytime and without previous notice, such modifications of components and accessories as might be deemed necessary for technical or commercial reasons, without any obligation to bring up-to-date this leaflet

La Castoldi S.p.A. si riserva il diritto di apportare, in qualsiasi momento e senza preavviso, eventuali modifiche di componenti ed accessori che ritiene necessarie per esigenze tecniche o commerciali, senza ritenersi impegnata ad aggiornare questa pubblicazione



CASTOLDI S.p.A.
Strada Provinciale 114 n.10 - 20080 ALBAIRATE (MI) - Italia
tel. +39 02 9401881 - fax +39 02 94018850
info@castoldijet.it